

Measurements of top quark mass and properties in ATLAS

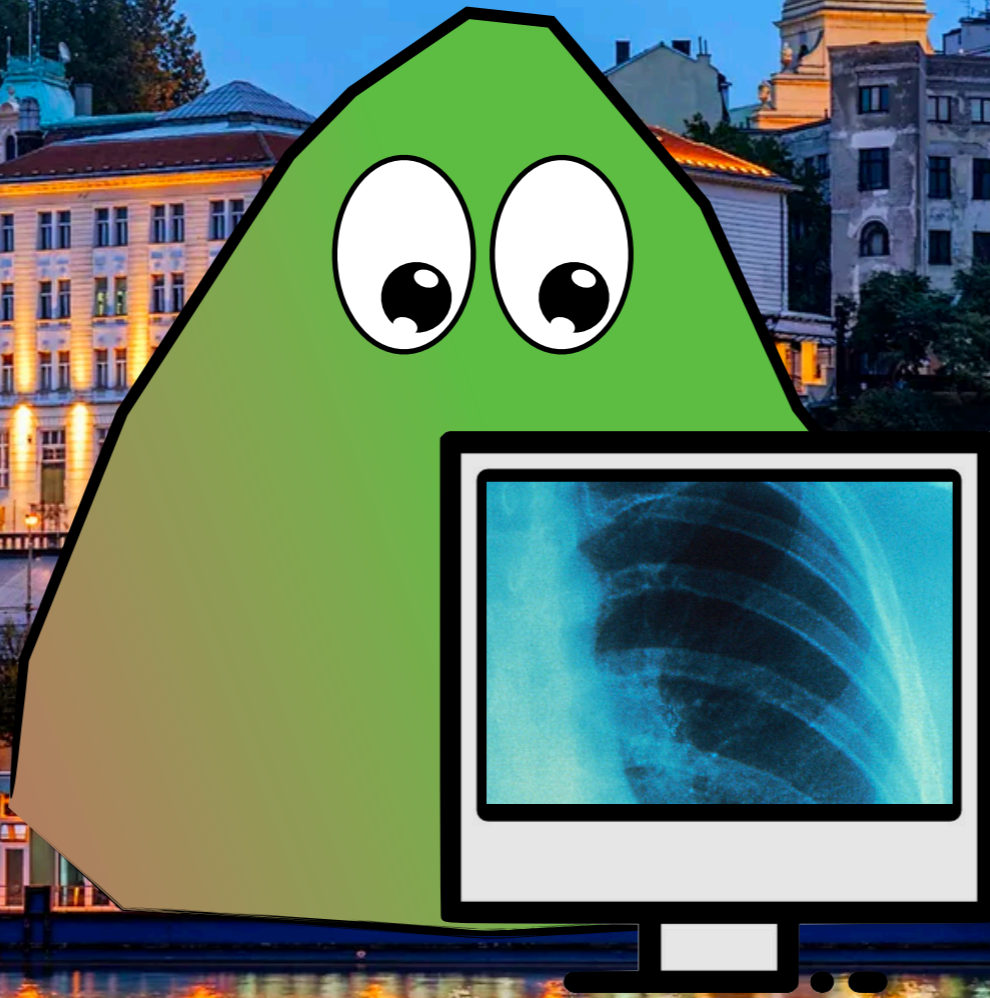

11th Large Hadron Collider Physics
Conference, Belgrade

Jay Howarth

- **Ideally, we want to know the quantum numbers of the quarks:**
 - ➔ **mass**
 - ➔ **spin**
 - ➔ **charge**
- **Properties of QCD** (particularly quark confinement) **makes it nearly impossible to access these directly for most quarks....**

- The top quark has a special and totally unique property: it is **VERY** heavy!
- It has a mass of 172.5 GeV, many orders of magnitude heavier than the other quarks!
- Closest in mass to an entire Rhenium nucleus.

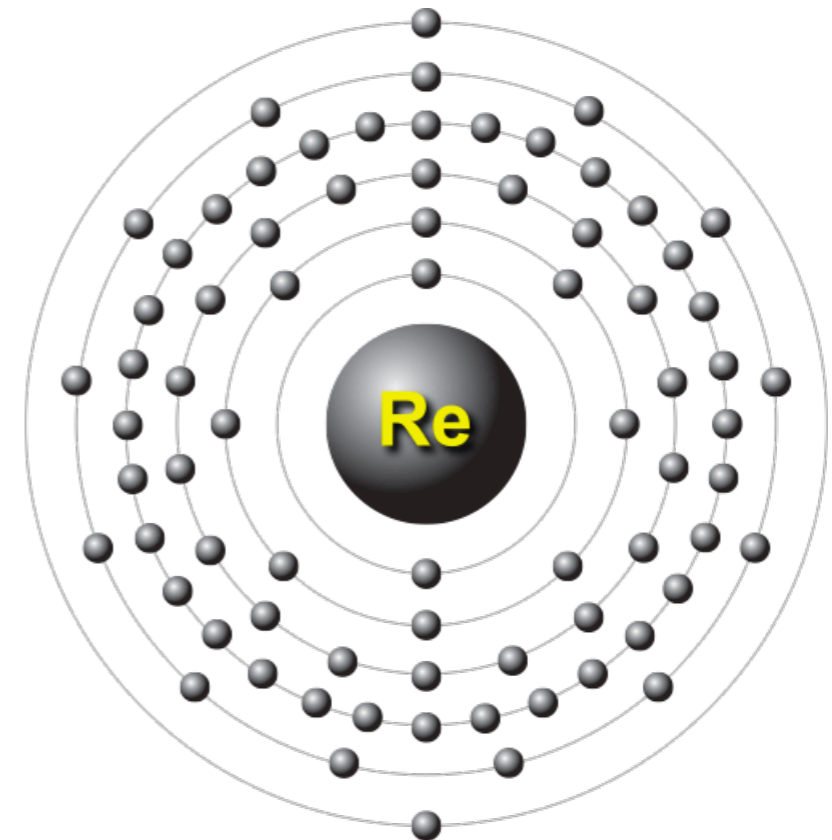

- This phenomenally high mass leads to some unique properties:

Production	Lifetime	Hadronisation	Spin decorr.
$\frac{1}{m(t)} \ll$	$\frac{1}{\Gamma(t)} \ll$	$\frac{1}{\Lambda_{QCD}} \ll$	$\frac{m(t)}{\Lambda_{QCD}}$
$\sim 10^{-27} \text{ s}$	$\sim 10^{-25} \text{ s}$	$\sim 10^{-24} \text{ s}$	$\sim 10^{-22} \text{ s}$

- QCD has no time to dilute its quantum numbers
- Perfect candidate to understand QCD!

Top Mass

- **A simple and accessible question at the LHC is “are we in a local or global minima?”.**

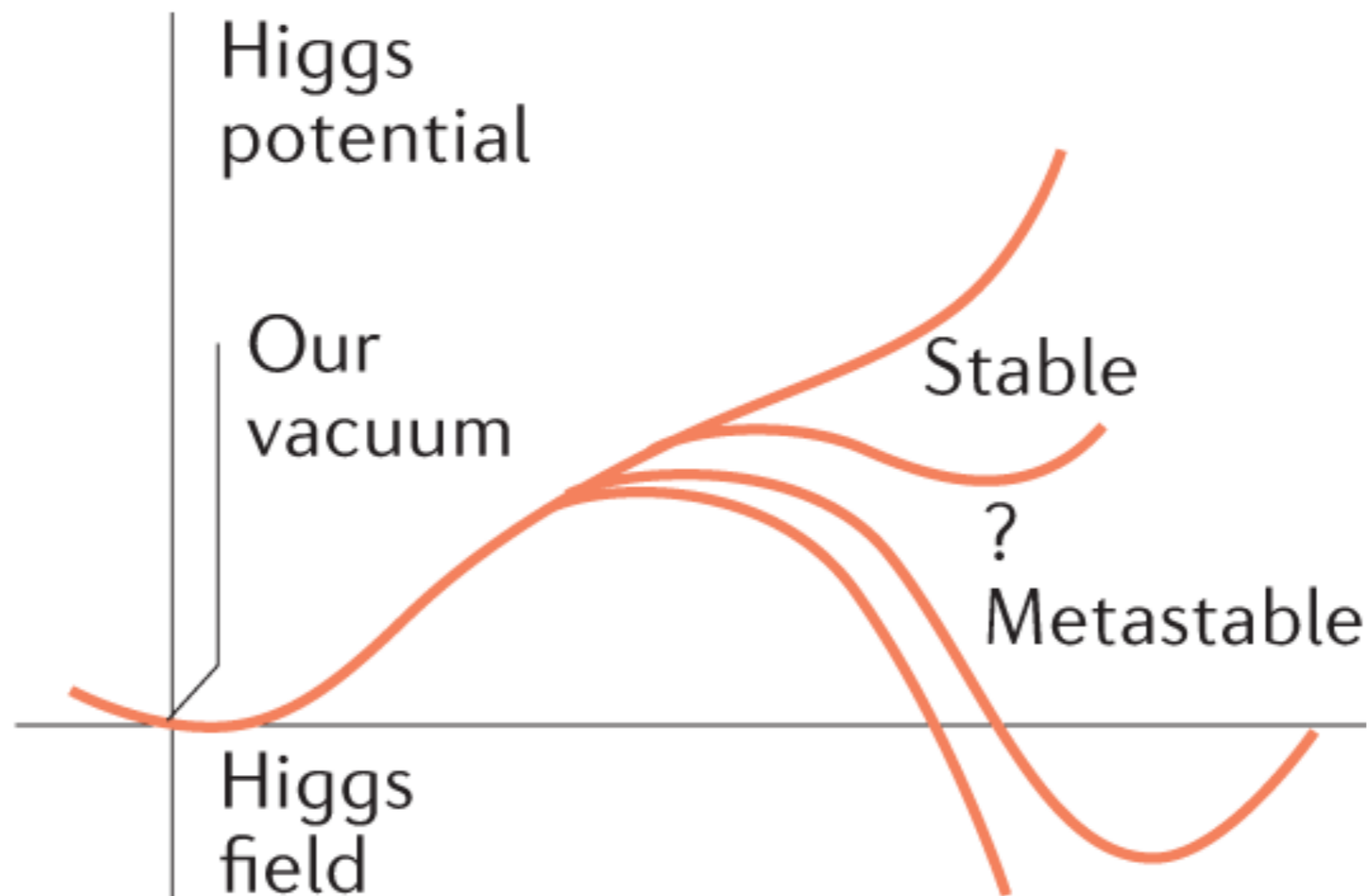

- **Measuring m_W , m_t , m_H can tell us.**

Fate of the Universe

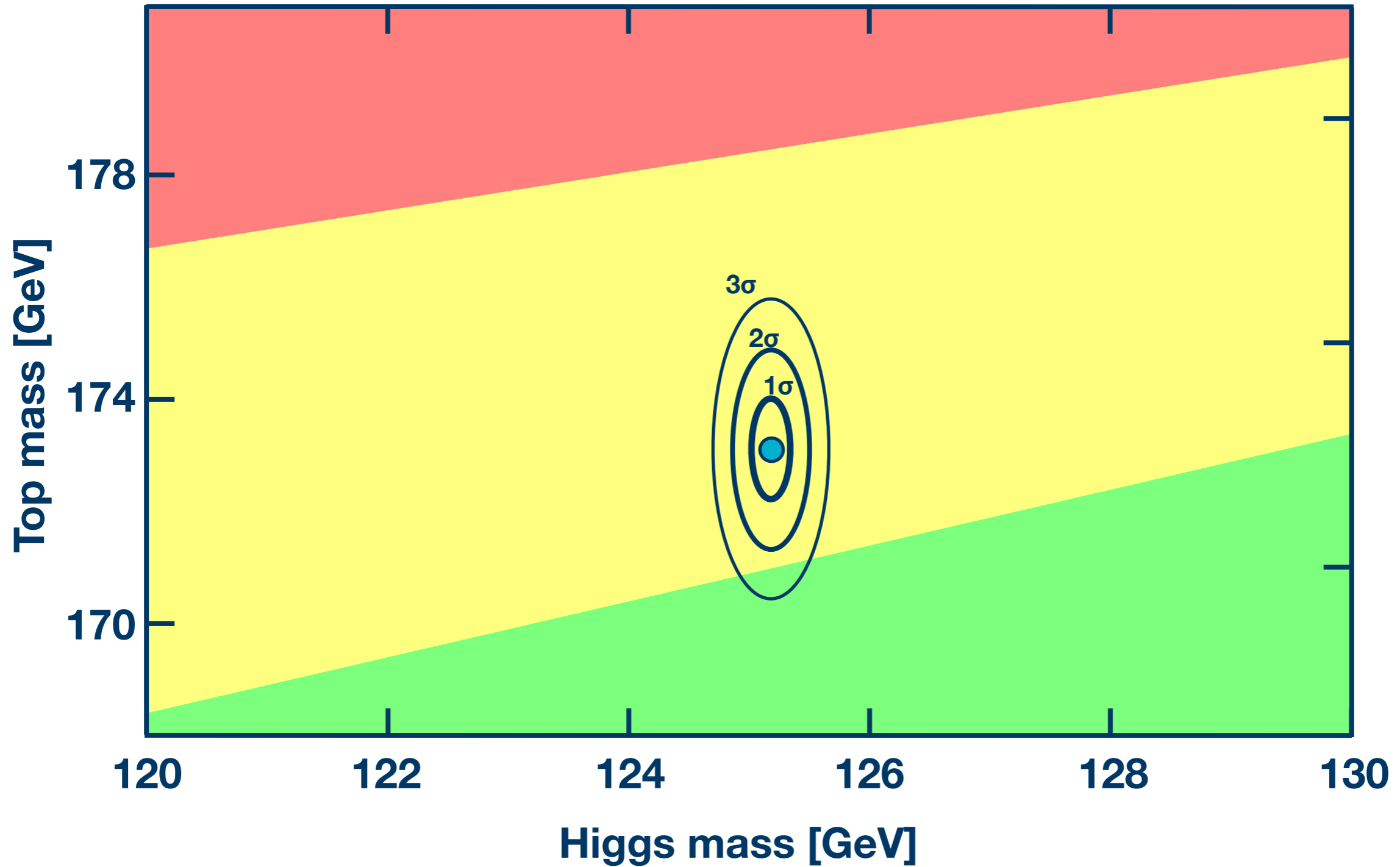

How do we measure it?

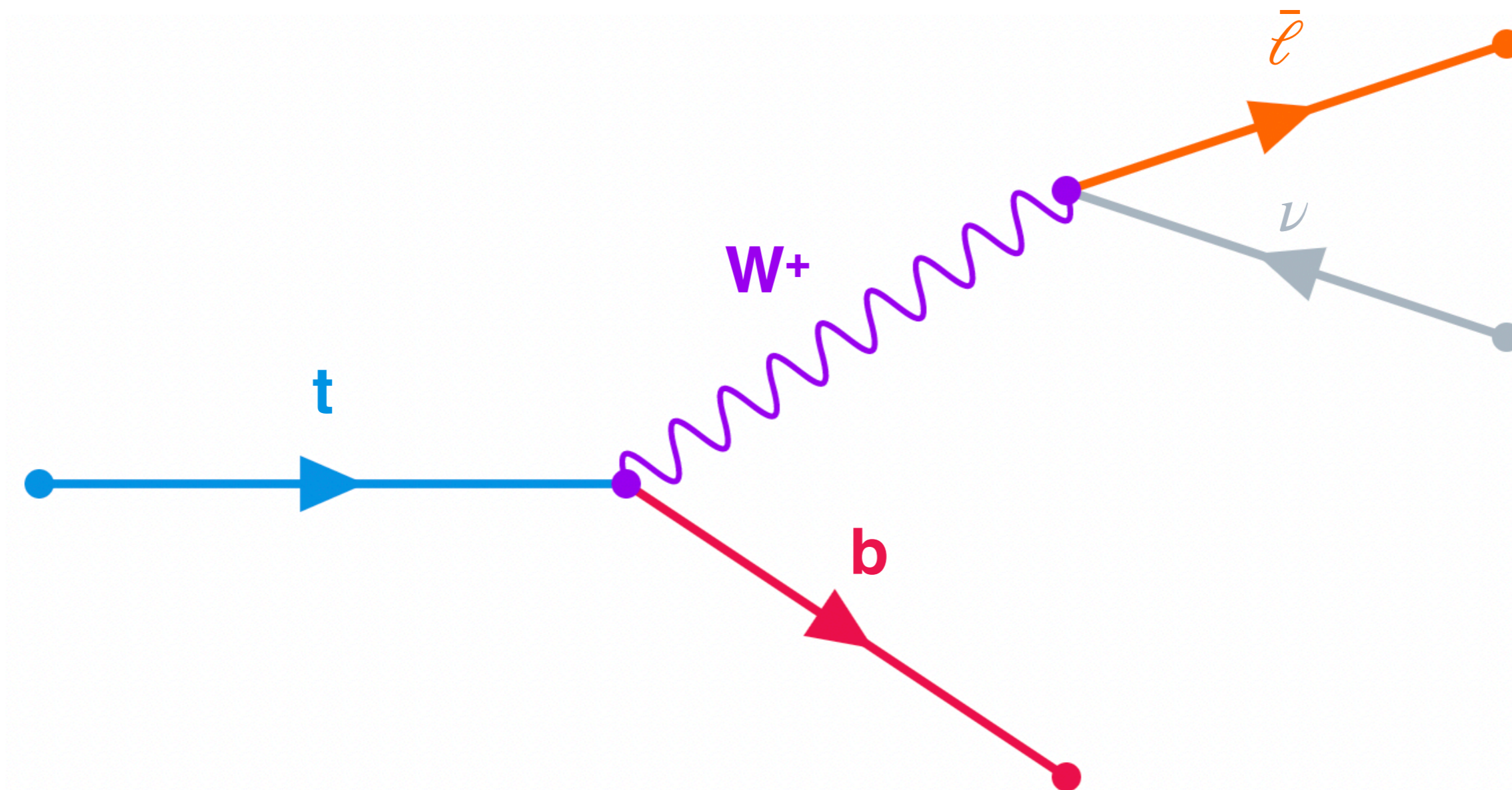

How do we measure it?

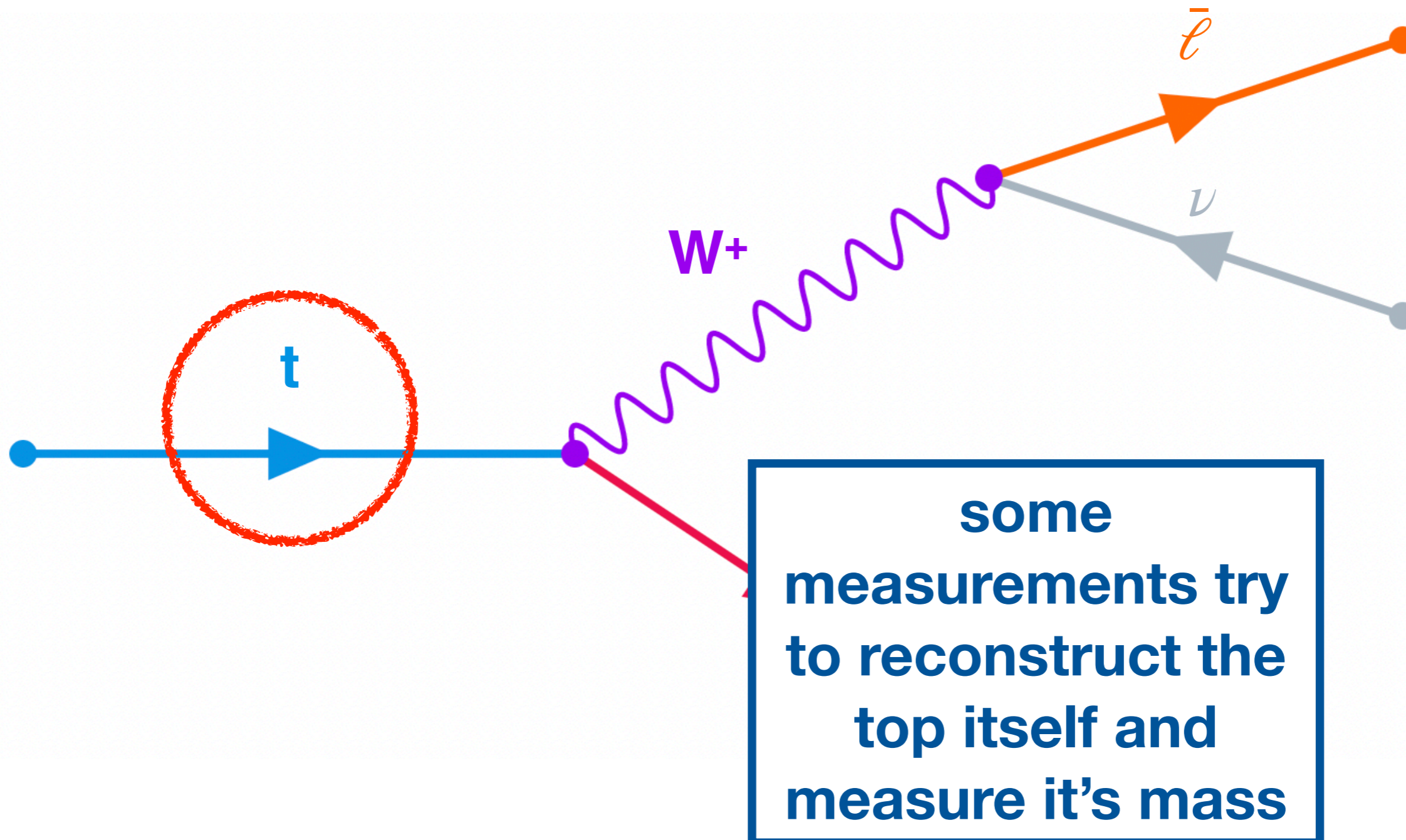

How do we measure it?

measurements I'll
show today focus
on observables
involving daughter
particles.

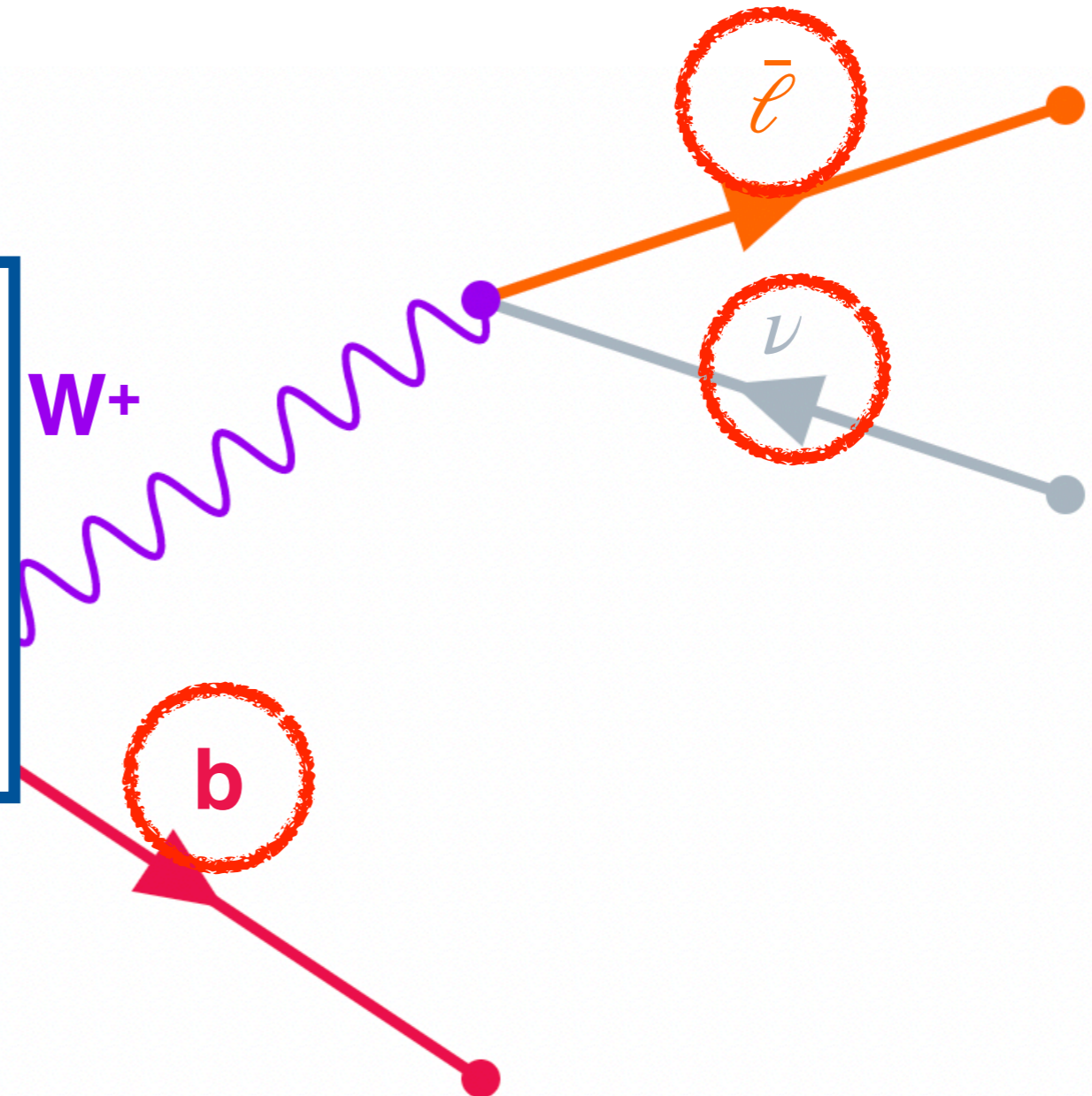

How do we measure it?

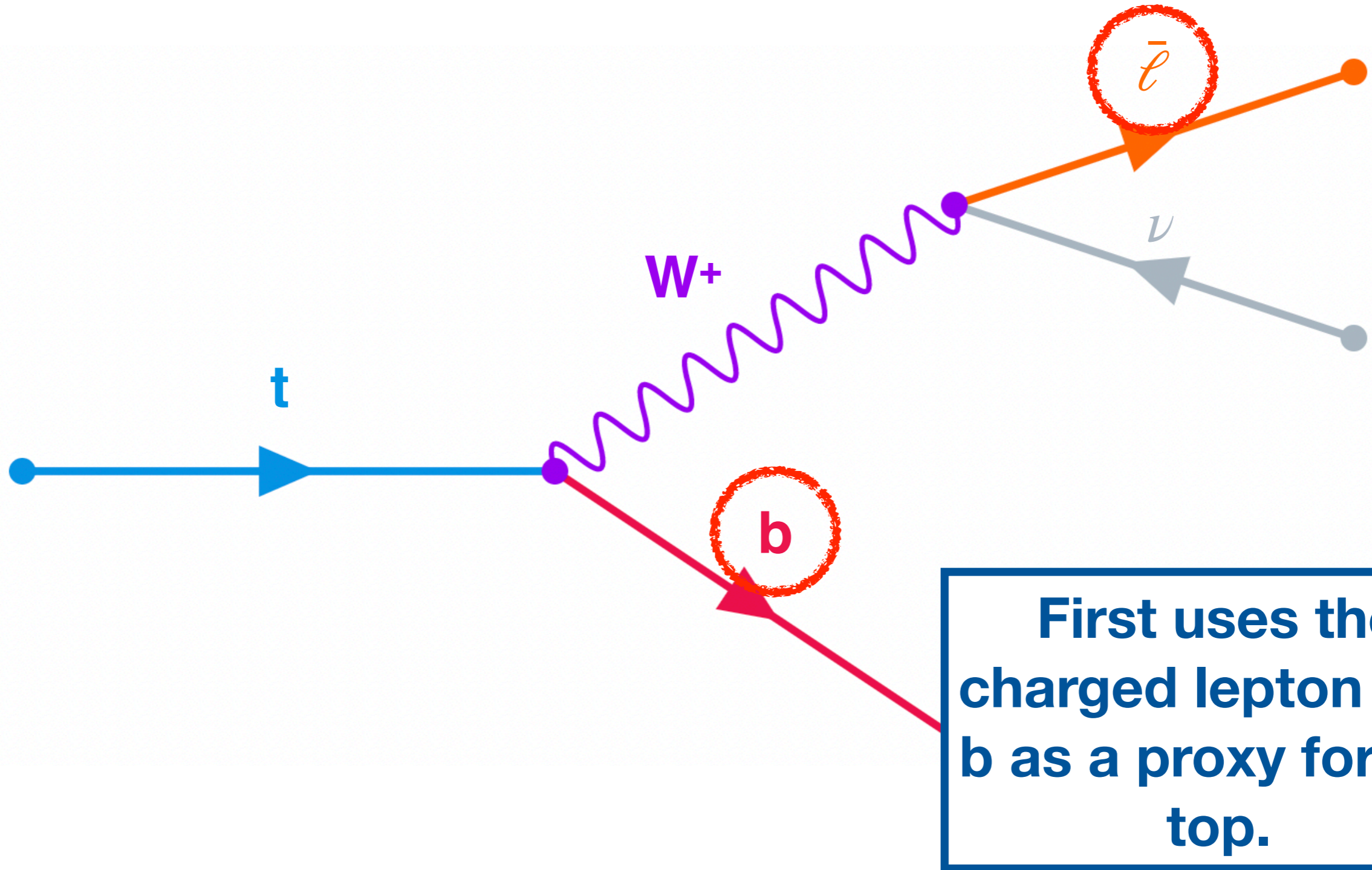

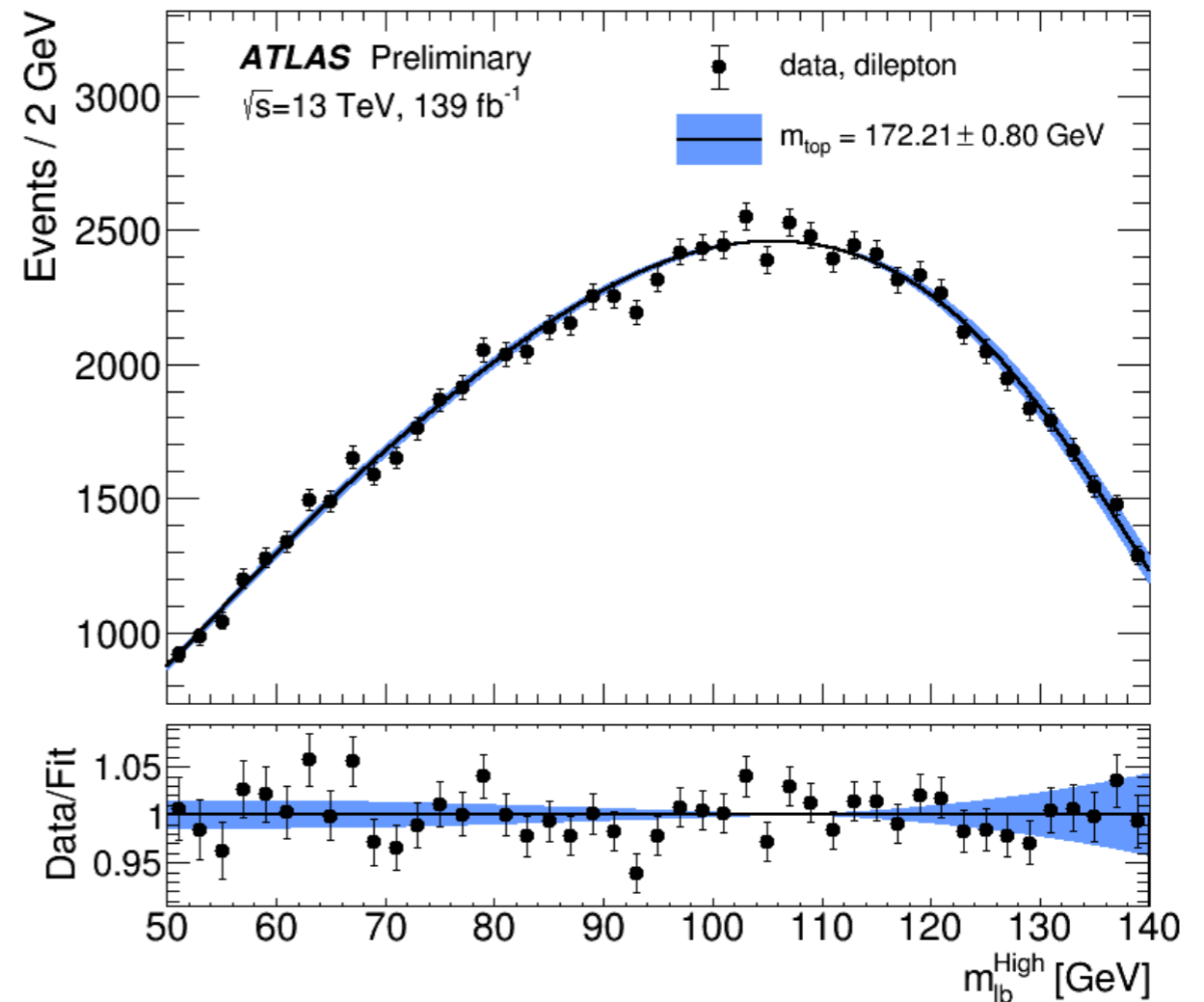
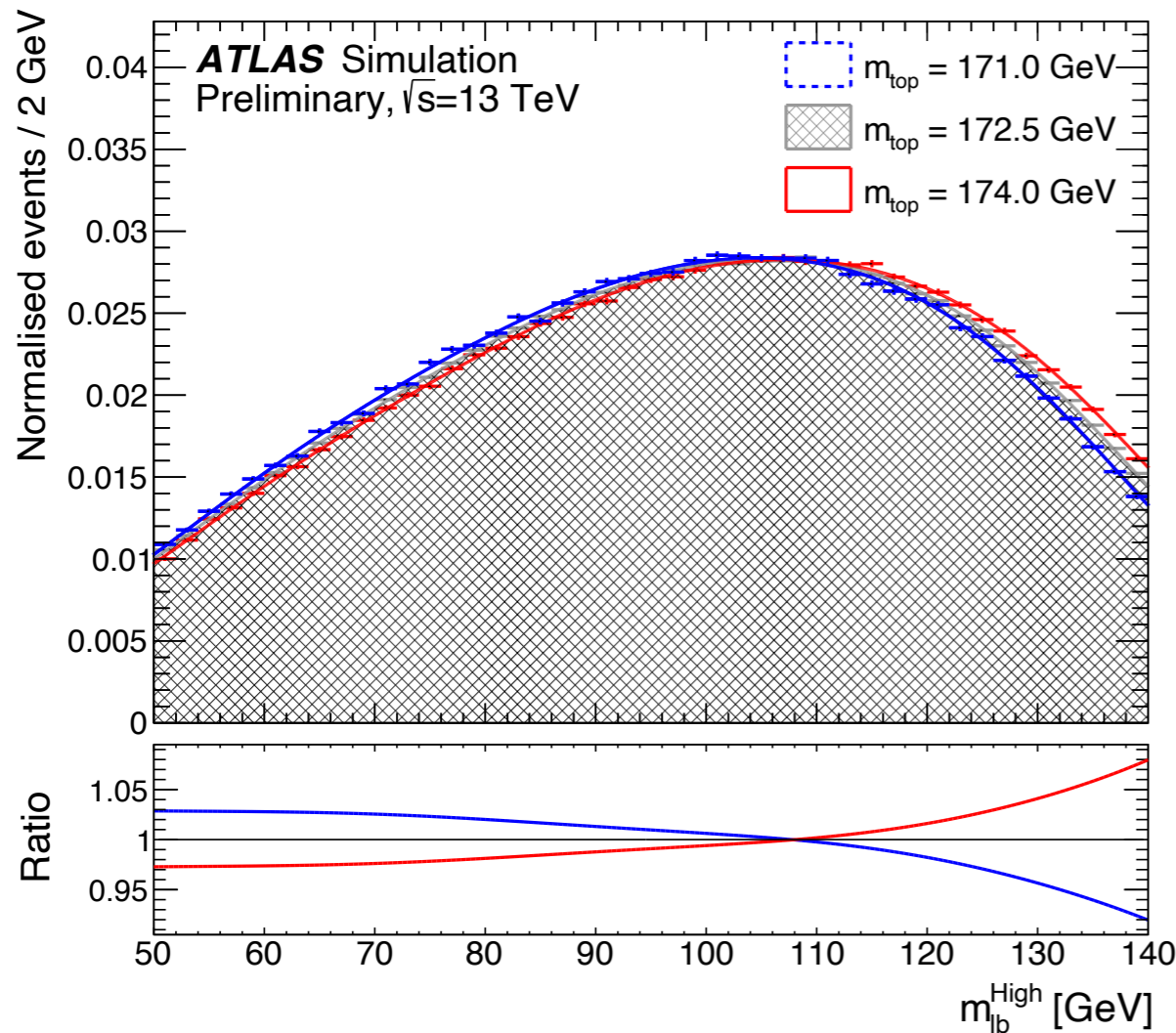

- **Top mass measured in proxy observable (m_{lb}) using template fit.**
- **Templates functions constructed from different mass hypotheses and fit to data (unbinned max likelihood fit).**

- **Final selection also uses DNN to resolve lepton-jet pairing ambiguity.**

	m_{top} [GeV]
Result	172.21
Statistics	0.20
Matrix-element matching	0.40
Colour reconnection	0.27
Recoil effect	0.39
Jet energy scale	0.37
Other uncertainties	0.29
Total uncertainty	0.80

*full table in backup

$$m_{\text{top}}^{\text{dilepton}} = 172.21 \pm 0.20 \text{ (stat)} \pm 0.67 \text{ (syst)} \pm 0.39 \text{ (recoil)} \text{ GeV.}$$

- **Uncertainty dominated by MC modelling and Jet energy scale uncertainties.**

How do we measure it?

Next uses the charged lepton and a soft muon from b-hadron decays as a proxy for the top.

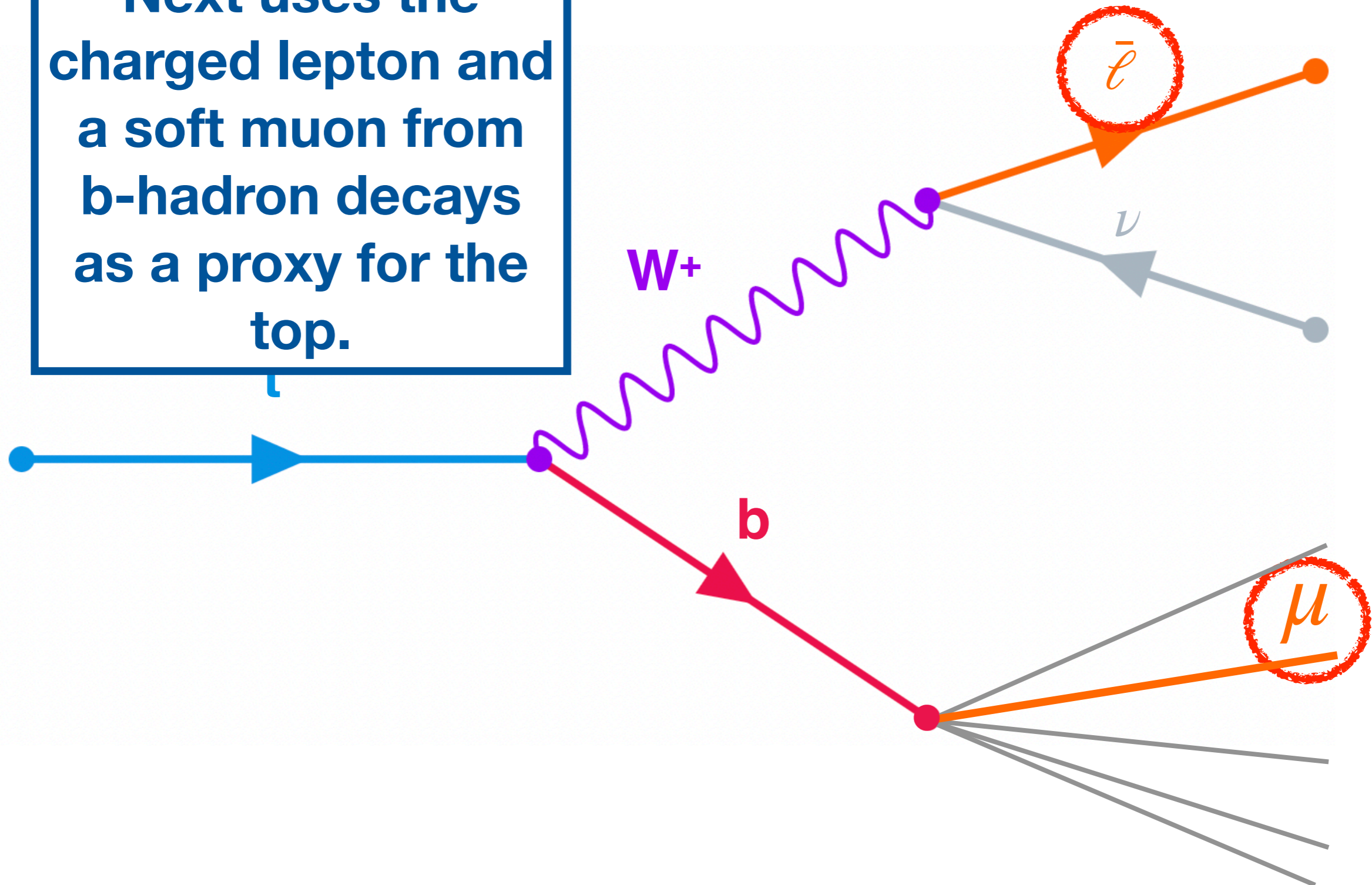

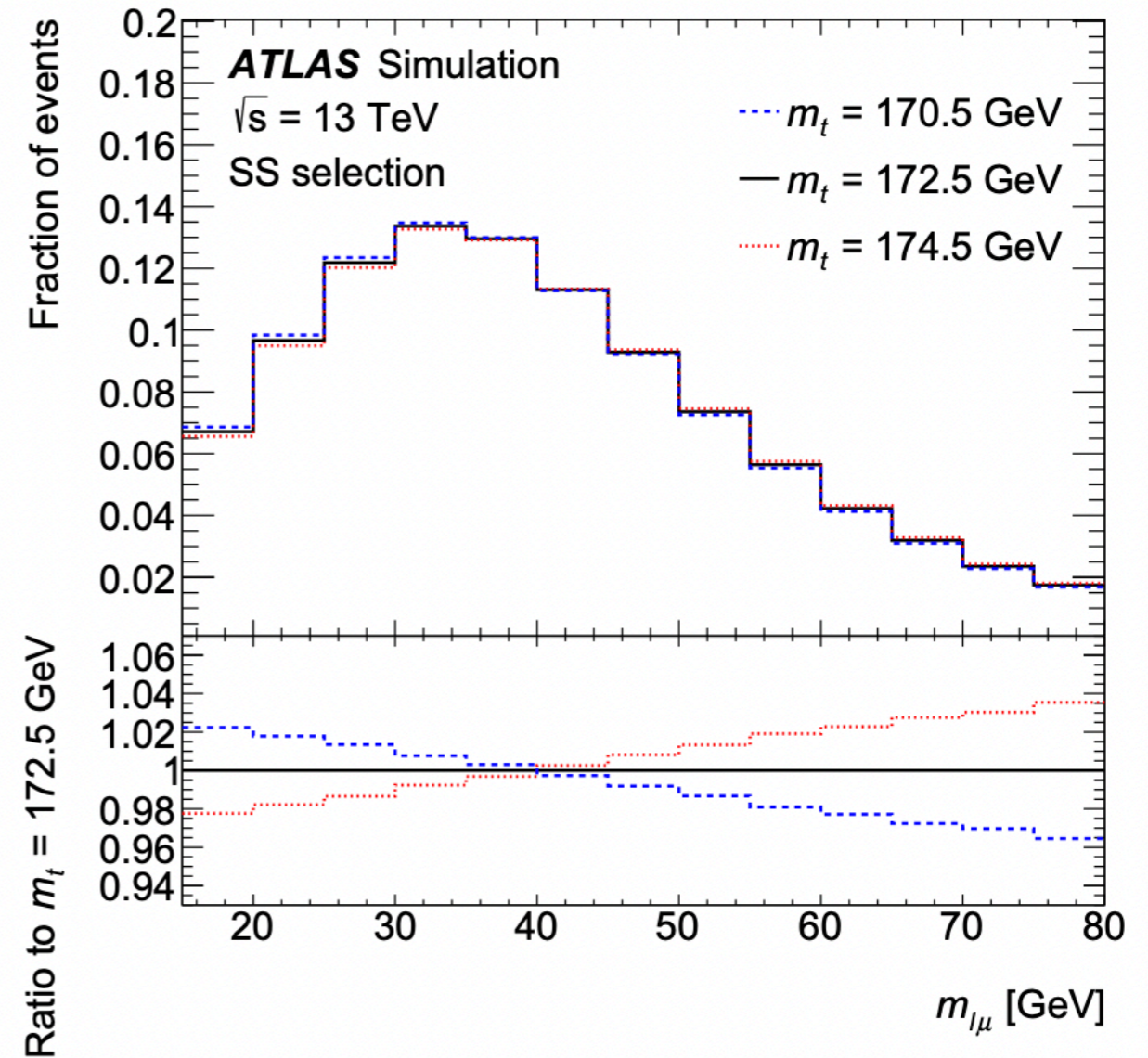
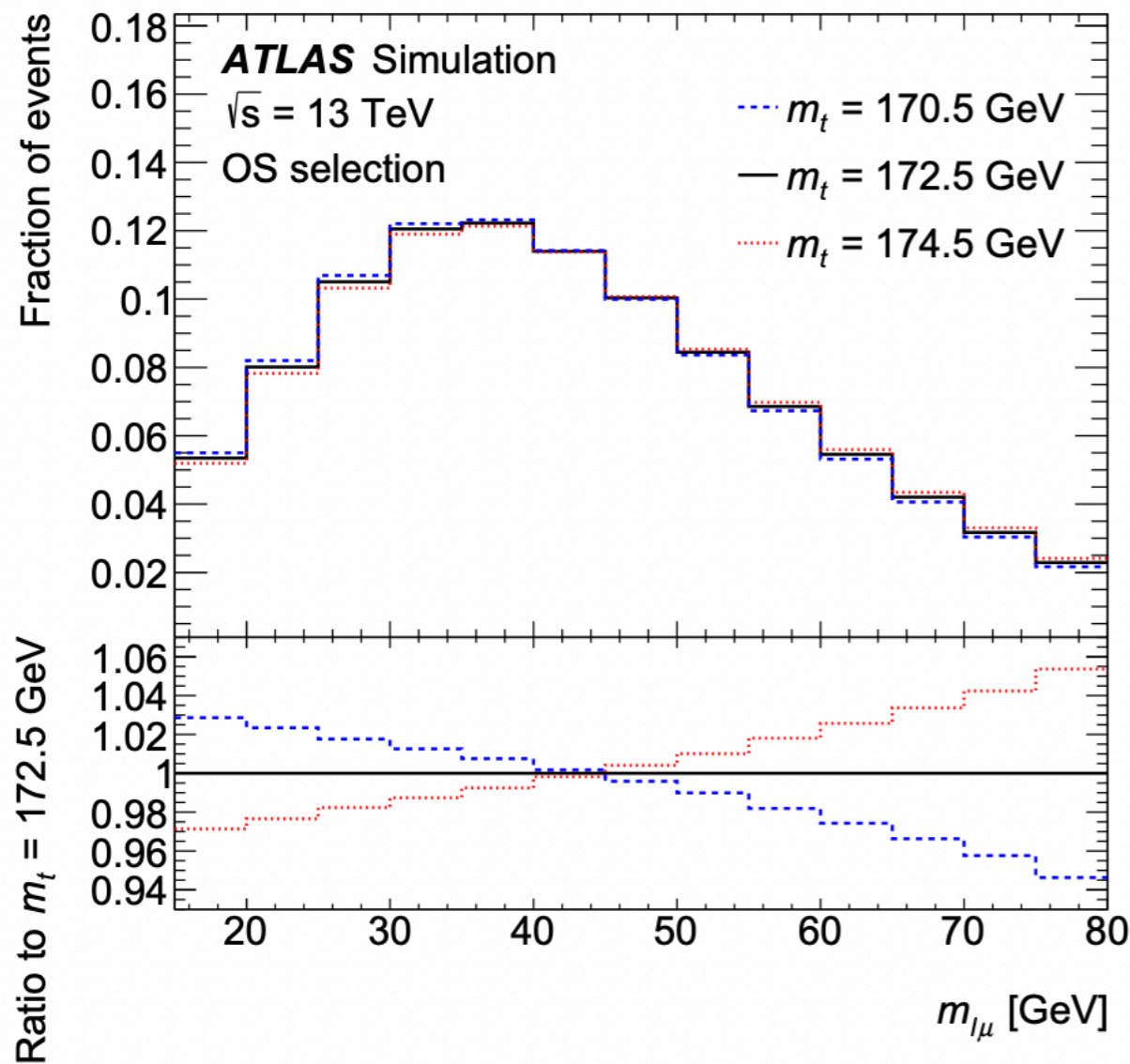

- **Similar to previous method but uses soft muon in b jet ($m_{l\mu}$); leptons measured more precisely than jets.**
- **Additional complication is μ and l can be same sign.**
- **Requires precise knowledge of b-fragmentation.**

- Mass extracted using binned maximum likelihood fit.

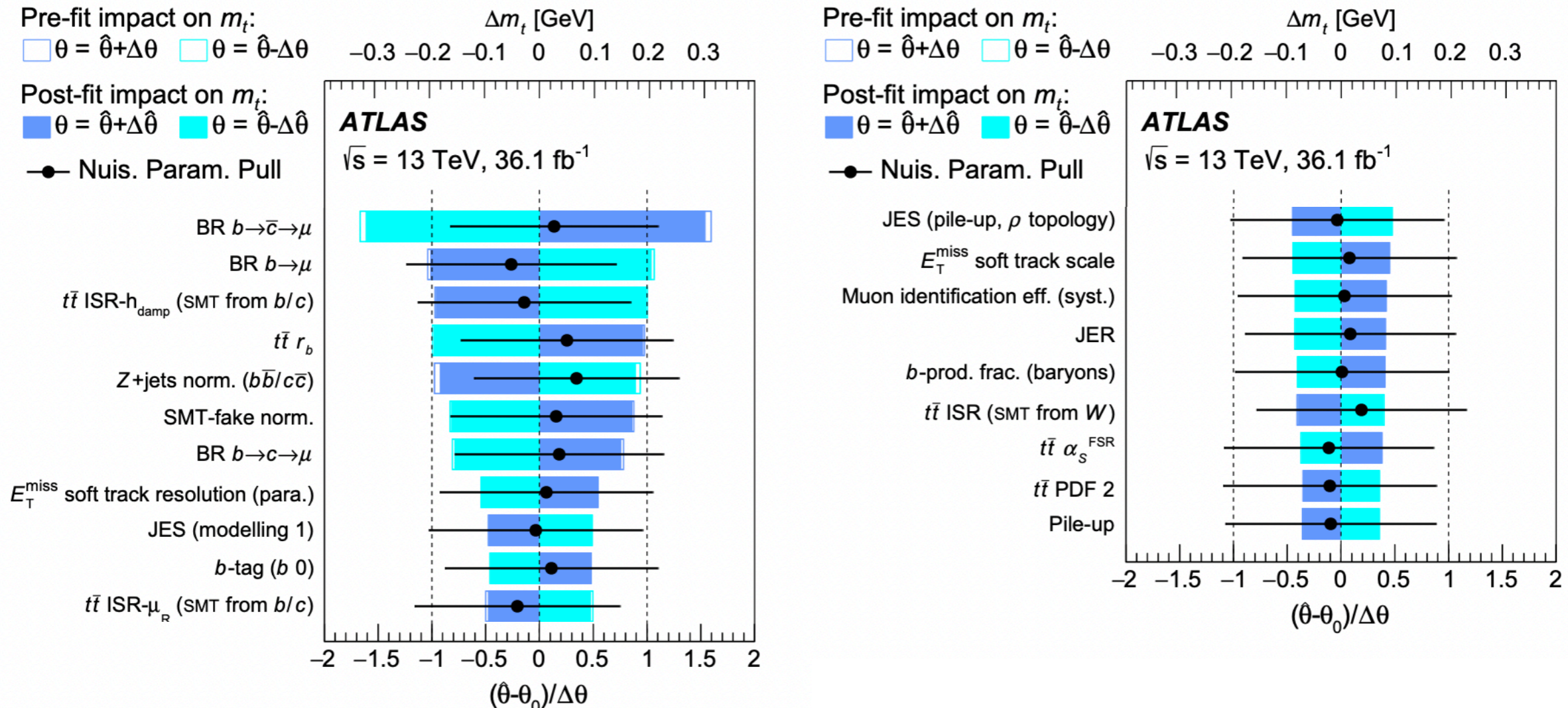

$$m_{\text{top}} = 174.41 \pm 0.39 \text{ (stat.)} \pm 0.66 \text{ (syst.)} \pm 0.25 \text{ (recoil) GeV}$$

- Measurement dominated by uncertainties on the b-fragmentation and decay.

- Mass extracted using binned maximum likelihood fit.

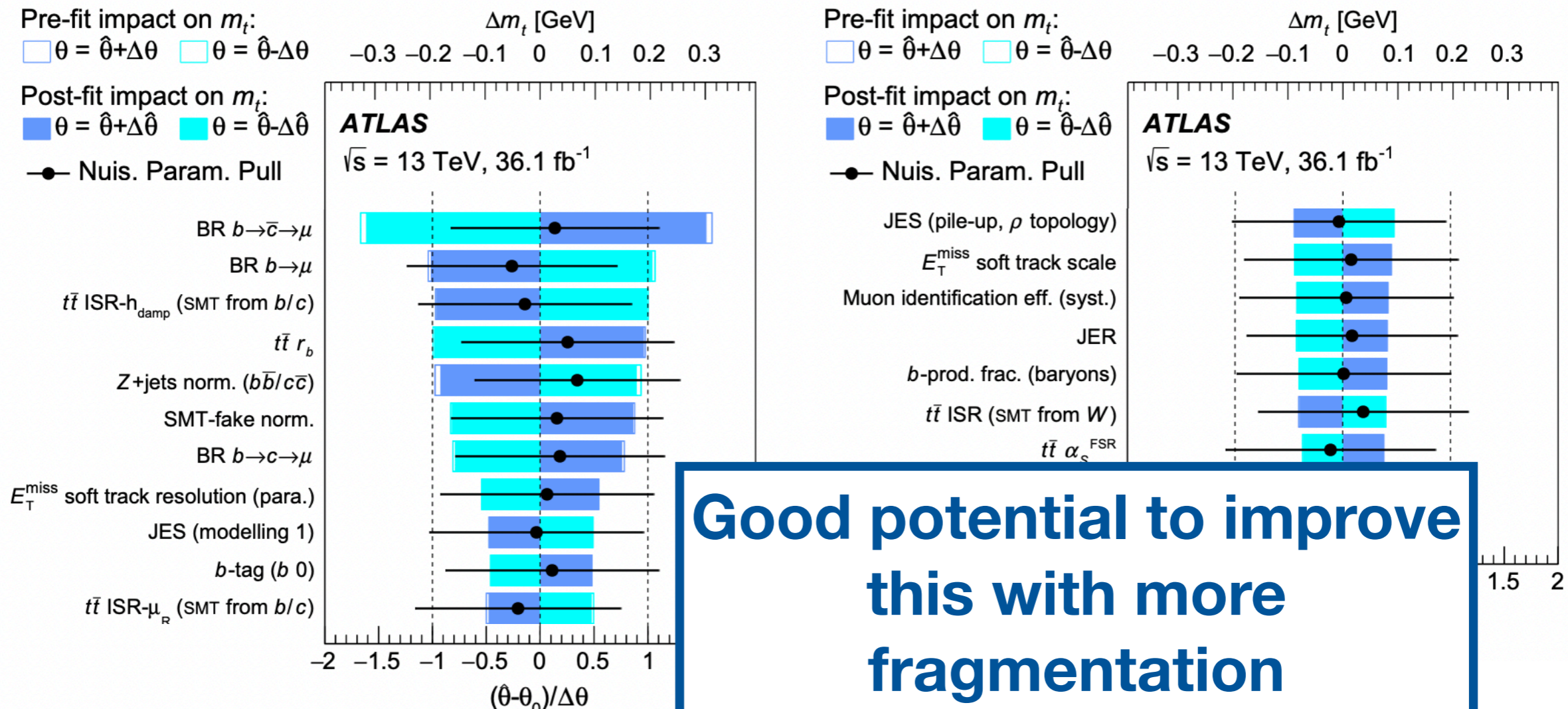

Good potential to improve this with more fragmentation improvements!

$$m_{\text{top}} = 174.41 \pm 0.39 \text{ (stat)}$$

GeV

- Measurement dominated by uncertainties on the b-fragmentation and decay.

Other Properties

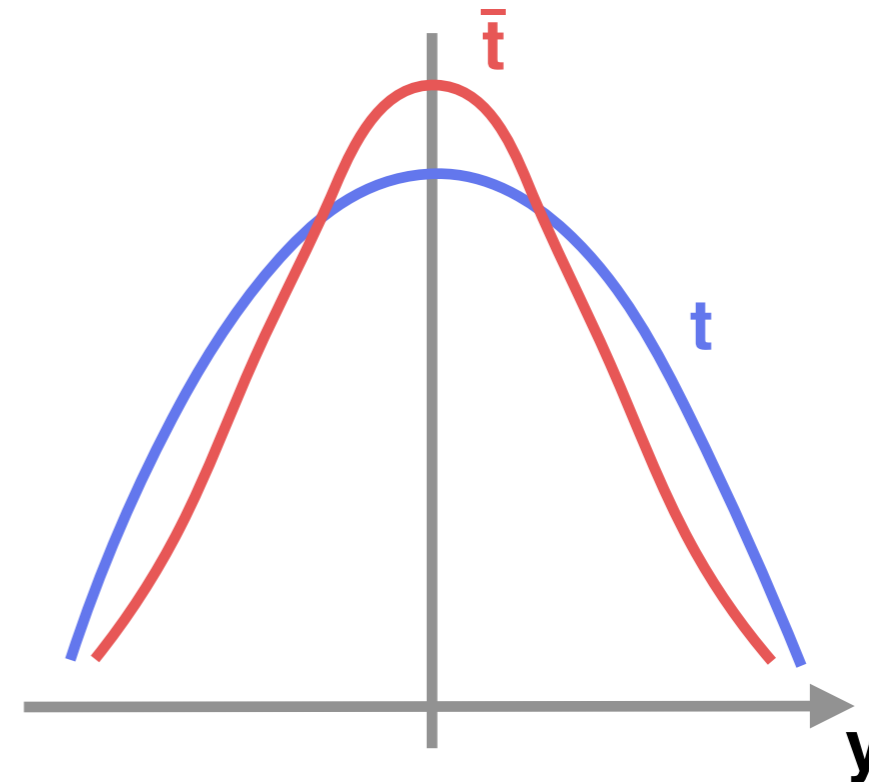
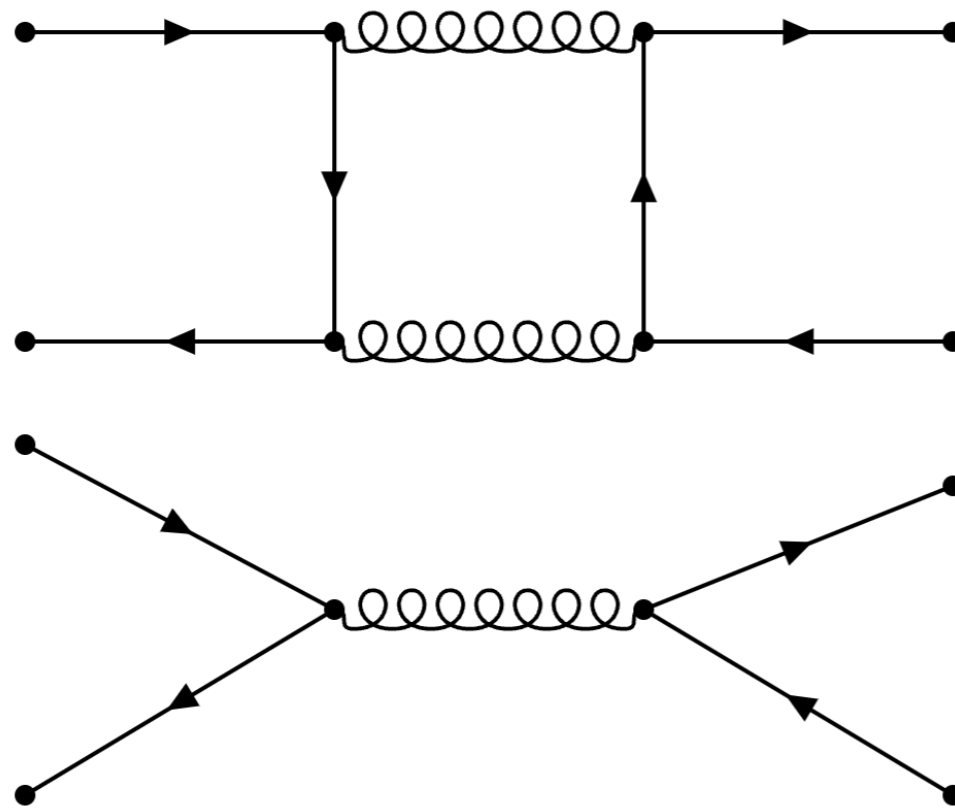

- **Interference between born and box diagrams induces an asymmetry in the direction of tops vs. anti-tops.**
- **Extremely subtle precent-level (0.6%) effect.**
(one of the most precise SM tests in top physics).

- **This measurement selected dileptonic and semi-leptonic (resolved and boosted) $t\bar{t}$ events and uses builds two asymmetries:**

$$A_C^{t\bar{t}} = \frac{N(\Delta|y_{t\bar{t}}| > 0) - N(\Delta|y_{t\bar{t}}| < 0)}{N(\Delta|y_{t\bar{t}}| > 0) + N(\Delta|y_{t\bar{t}}| < 0)} \quad \Delta|y_{t\bar{t}}| = |y_t| - |y_{\bar{t}}|$$

$$A_C^{\ell\bar{\ell}} = \frac{N(\Delta|\eta_{\ell\bar{\ell}}| > 0) - N(\Delta|\eta_{\ell\bar{\ell}}| < 0)}{N(\Delta|\eta_{\ell\bar{\ell}}| > 0) + N(\Delta|\eta_{\ell\bar{\ell}}| < 0)} \quad \Delta|\eta_{\ell\bar{\ell}}| = |\eta_{\bar{\ell}}| - |\eta_{\ell}|$$

- **Observables are corrected for detector effects using a Fully Bayesian Unfolding.**
- **Systematic uncertainties are marginalised and can be constrained by the data.**

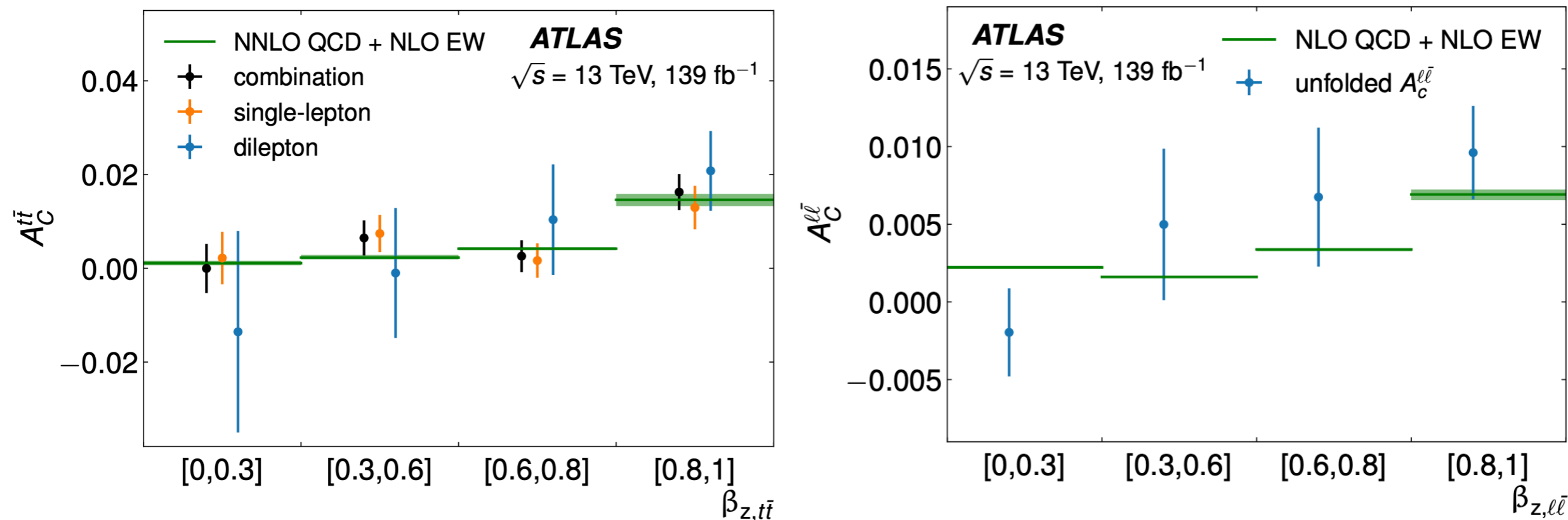

- **Measured inclusive asymmetries are:**

$$A_C^{t\bar{t}} = 0.068 \pm 0.015 \text{ (stat. + syst.)}$$

$$A_C^{\parallel} = 0.054 \pm 0.026 \text{ (stat. + syst.)}$$

- **4.7 sigma disagreement with 0: very strong evidence!**

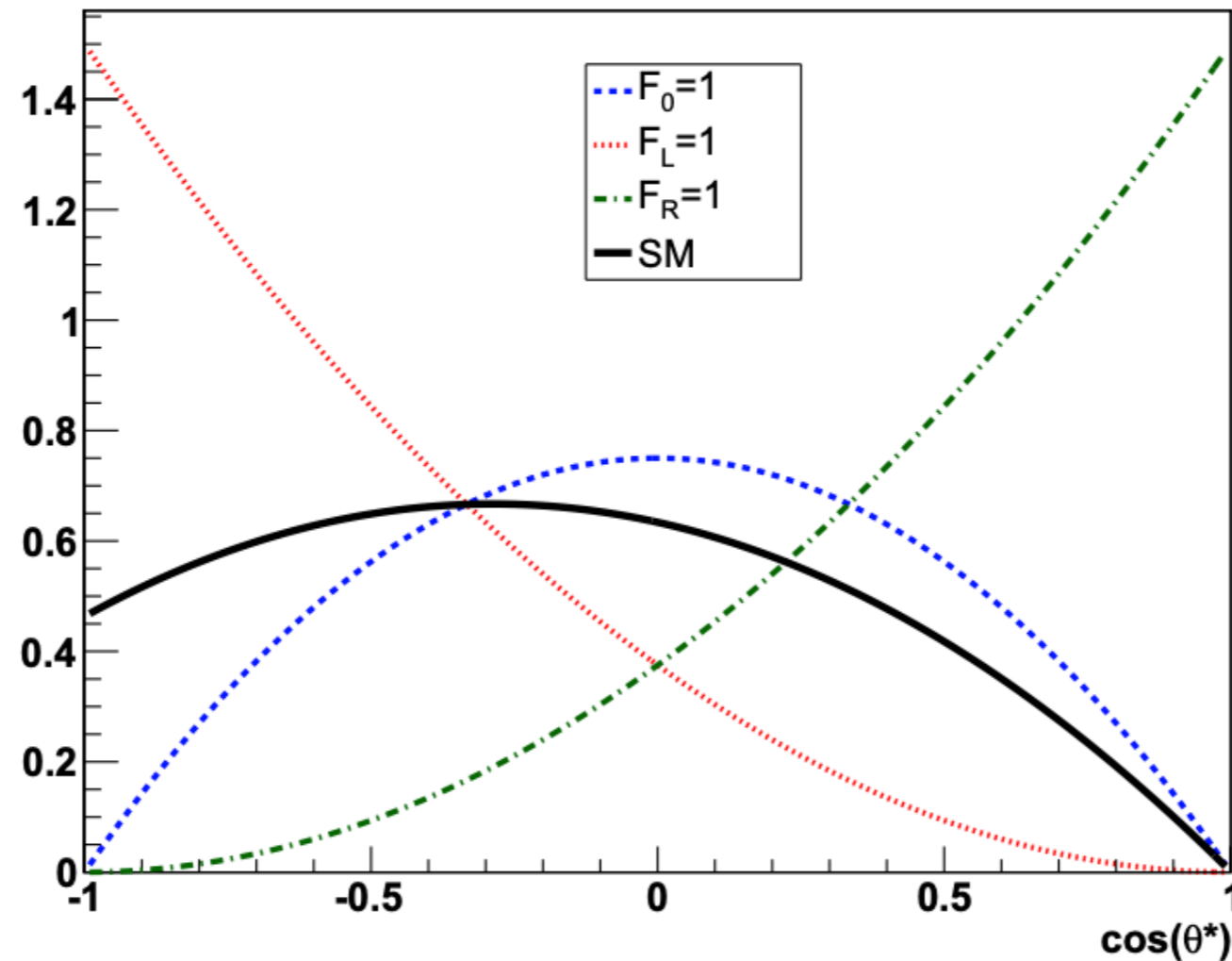

- **W bosons can be polarised longitudinally (F_0) or left-handed (F_L), but not right-handed (F_R) in the SM.**
- **Sensitive to anomalous Wtb couplings** (any significant $F_R =$ new physics!).

$$\frac{1}{\sigma} \frac{d\sigma}{d \cos \theta^*} = \frac{3}{4} (1 - \cos^2 \theta^*) f_0 + \frac{3}{8} (1 - \cos \theta^*)^2 f_L + \frac{3}{8} (1 + \cos \theta^*)^2 f_R.$$

- Measured by unfolding using angular distribution of charged lepton decay from the W.

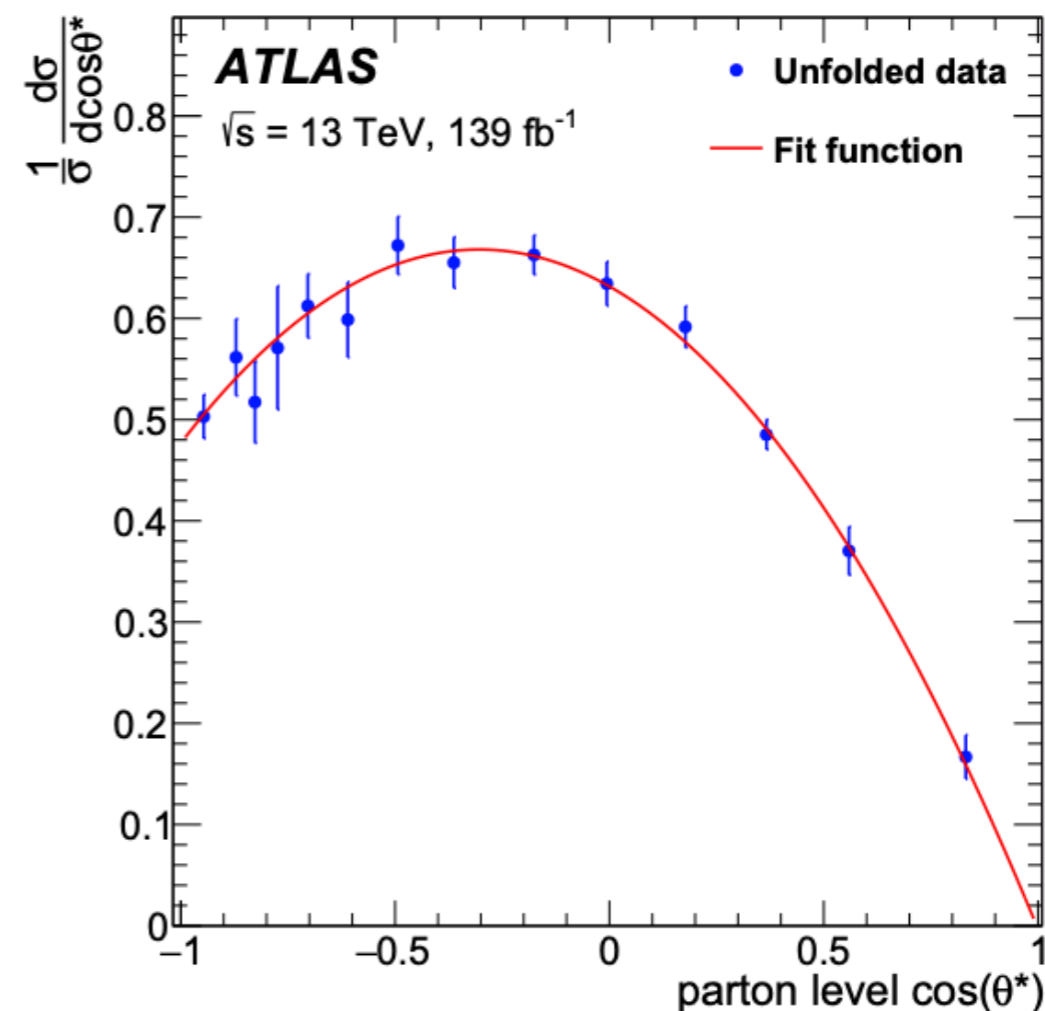
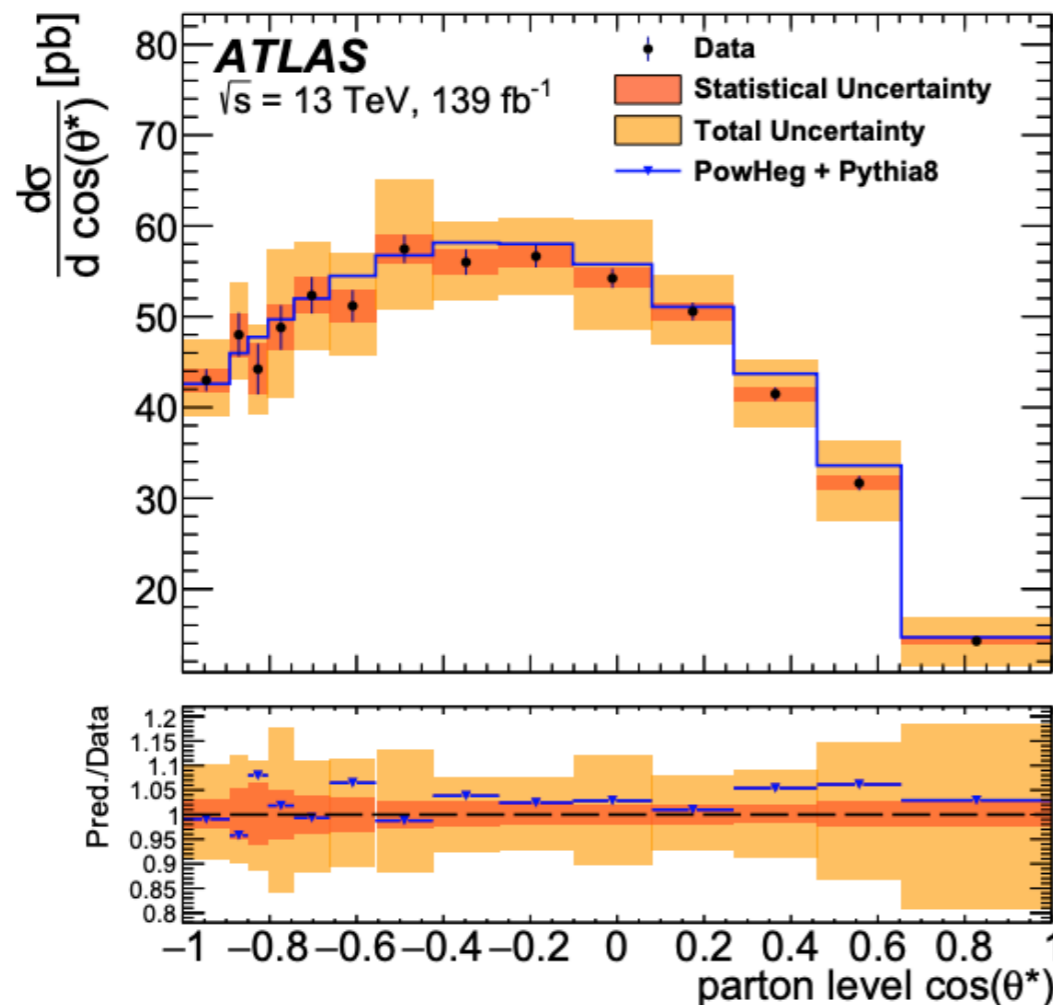

$$\frac{1}{\sigma} \frac{d\sigma}{d \cos \theta^*} = \frac{3}{4} (1 - \cos^2 \theta^*) f_0 + \frac{3}{8} (1 - \cos \theta^*)^2 f_L + \frac{3}{8} (1 + \cos \theta^*)^2 f_R.$$

- Measured by unfolding using angular distribution of charged lepton decay from the W.

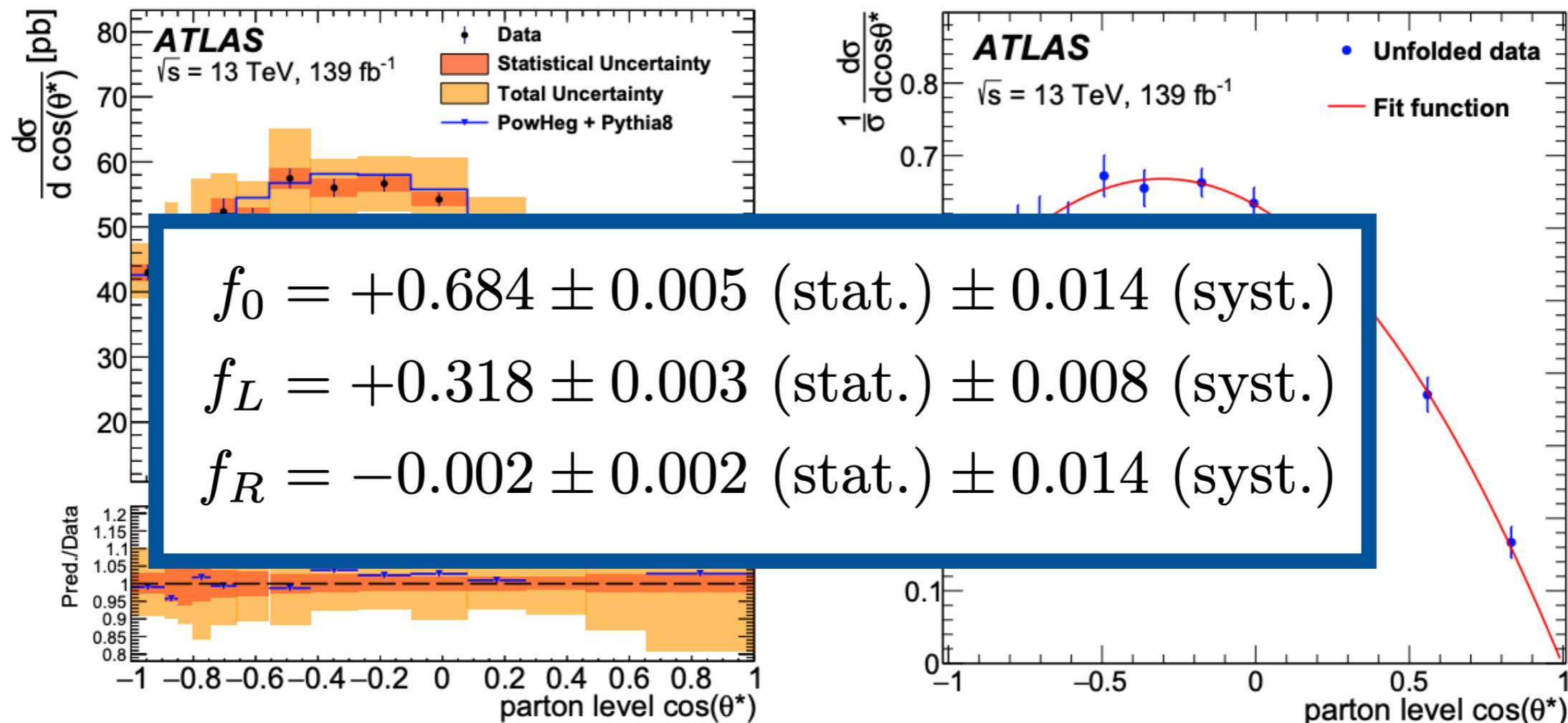

- **First ATLAS Run2 top mass measurements starting to appear.**
- **Current sensitivity is ~ 1 GeV, but this will decrease as more analyses mature.**
- **Precision tests of top-properties already well established in Run2, now approaching ultra-precise measurements.**
- **Still some clear statistical benefits from upcoming Run3 data in these analyses.**

Backup

- $t\bar{t}\gamma$ charge asymmetry: Accepted by PLB
- W Boson polarisation: Accepted by PLB
- top mass (SMT): Accepted by JHEP
- top mass (template): ATLAS-CONF-2022-058

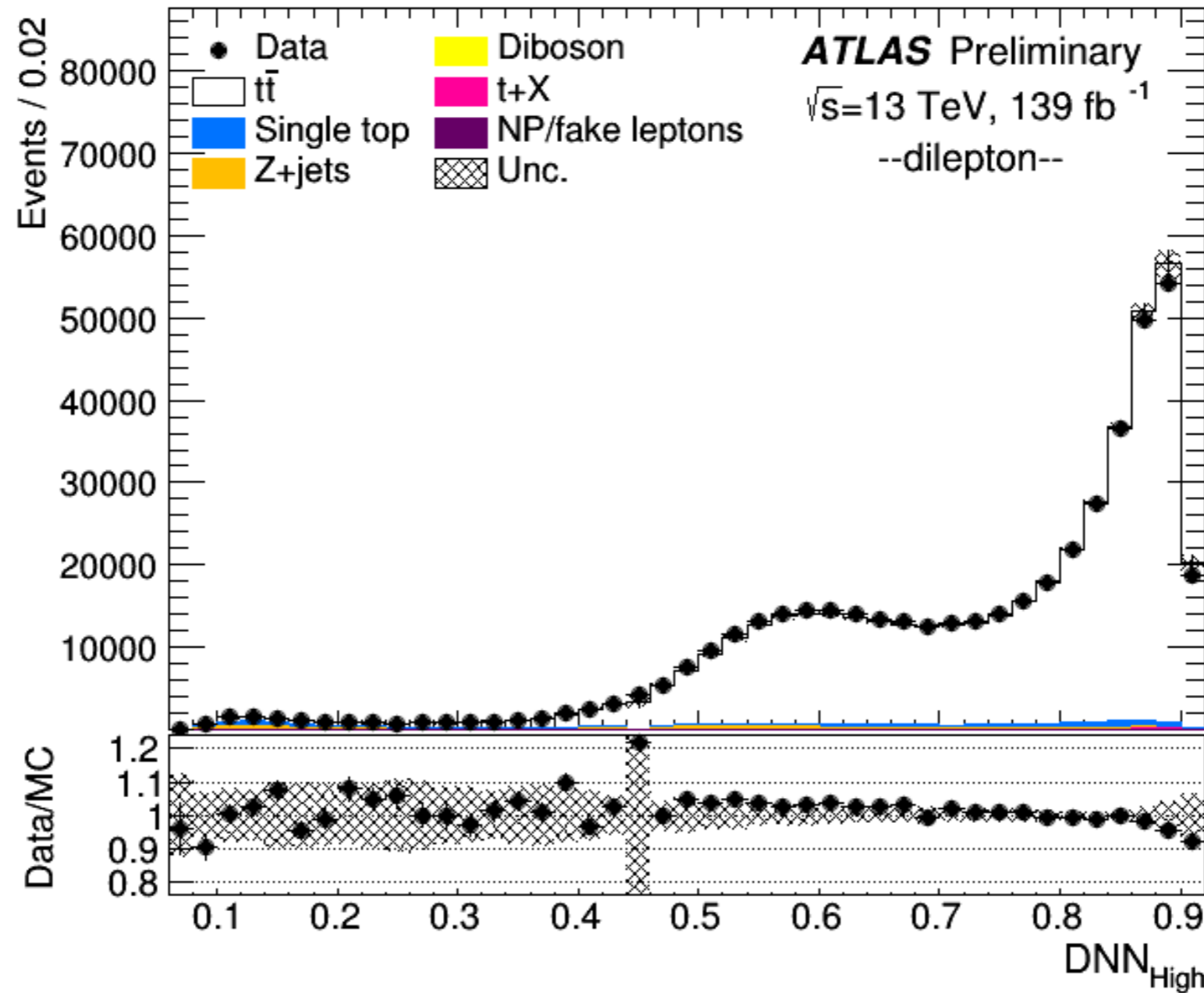

- **Deep Neural Net used to optimise lepton-b pairings.**

	m_{top} [GeV]
Result	172.21
Statistics	0.20
Method	0.05 ± 0.04
Matrix-element matching	0.40 ± 0.06
Parton shower and hadronisation	0.05 ± 0.05
Initial- and final-state QCD radiation	0.17 ± 0.02
Underlying event	0.02 ± 0.10
Colour reconnection	0.27 ± 0.07
Parton distribution function	0.03 ± 0.00
Single top modelling	0.01 ± 0.01
Background normalisation	0.03 ± 0.02
Jet energy scale	0.37 ± 0.02
b -jet energy scale	0.12 ± 0.02
Jet energy resolution	0.13 ± 0.02
Jet vertex tagging	0.01 ± 0.01
b -tagging	0.04 ± 0.01
Leptons	0.11 ± 0.02
Pile-up	0.06 ± 0.01
Recoil effect	0.39 ± 0.09
Total systematic uncertainty (without recoil)	0.67 ± 0.05
Total systematic uncertainty (with recoil)	0.77 ± 0.06
Total uncertainty (without recoil)	0.70 ± 0.05
Total uncertainty (with recoil)	0.80 ± 0.06